

MTE

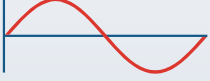

Meter Test Equipment

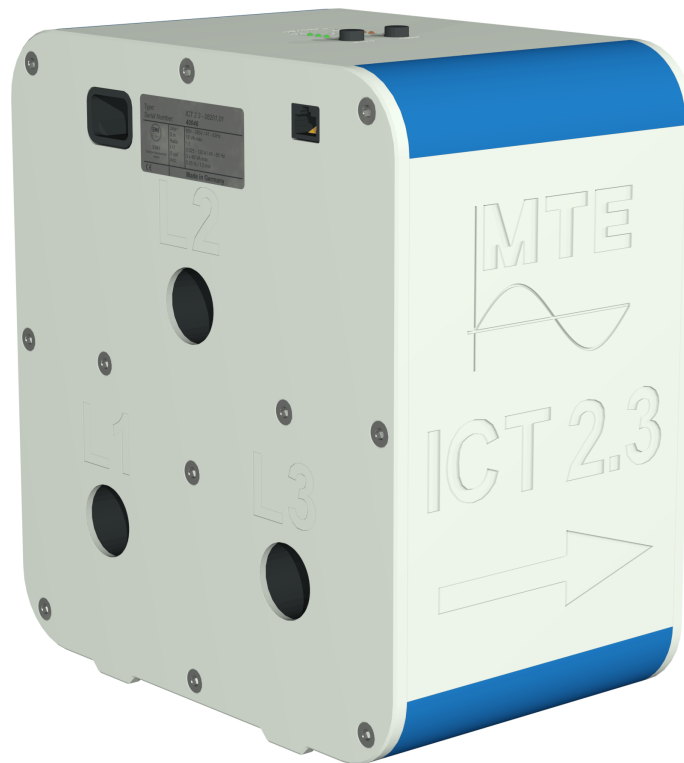

ICT 2.3 Three-phase Isolation Current Transformer

ICT 2.3 Isolation Current Transformer

The ICT 2.3 three-phase Isolation Current Transformer is used on multi position test benches for testing three-phase meters with closed links between the current and voltage measuring circuits (I-P links). Electronic meters with closed links are becoming increasingly common.

While testing meters with fix closed I-P links, unwanted connections between voltage and current path at each test position will cause significant accuracy reduction.

In this case transformers in the current circuit are required to decouple the voltage from the current path.

To achieve complete decoupling the test installation must be fitted with one current transformer per phase for each test position.

In this way each meter under test is supplied with isolated test currents via these toroidal-core current transformers, which have a current ratio of 1:1 and an amplitude and a phase error over the required current range small enough not to introduce significant additional errors.

Bloc diagram

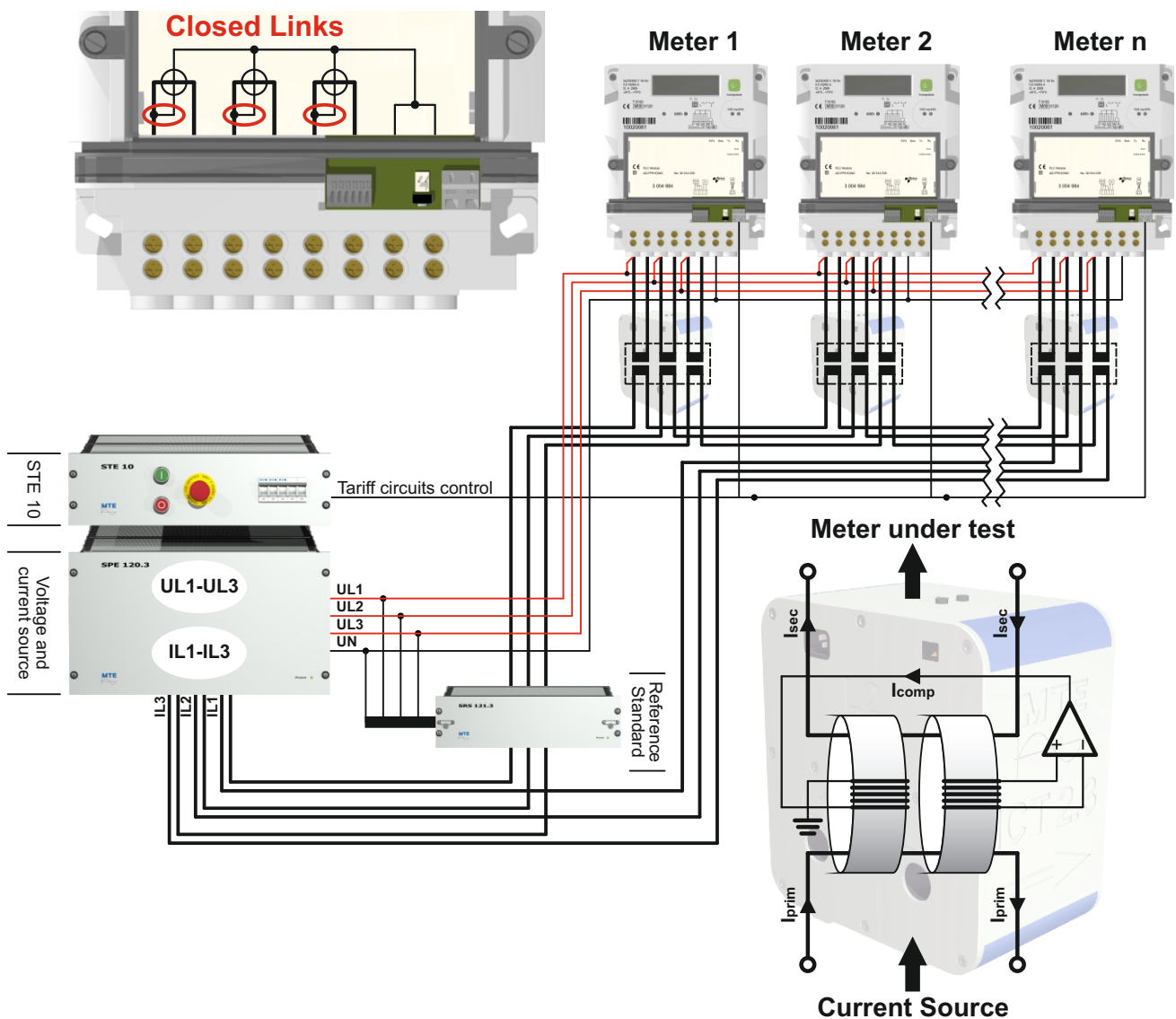

Current connection of meters

The ICT 2.3 performs the 1:1 current transformation with 1 winding by passing the primary and secondary current cable through the same hole. A big advantage of the connection through a hole is, that the same secondary current cables can be used for operation with ICT or for direct connection.

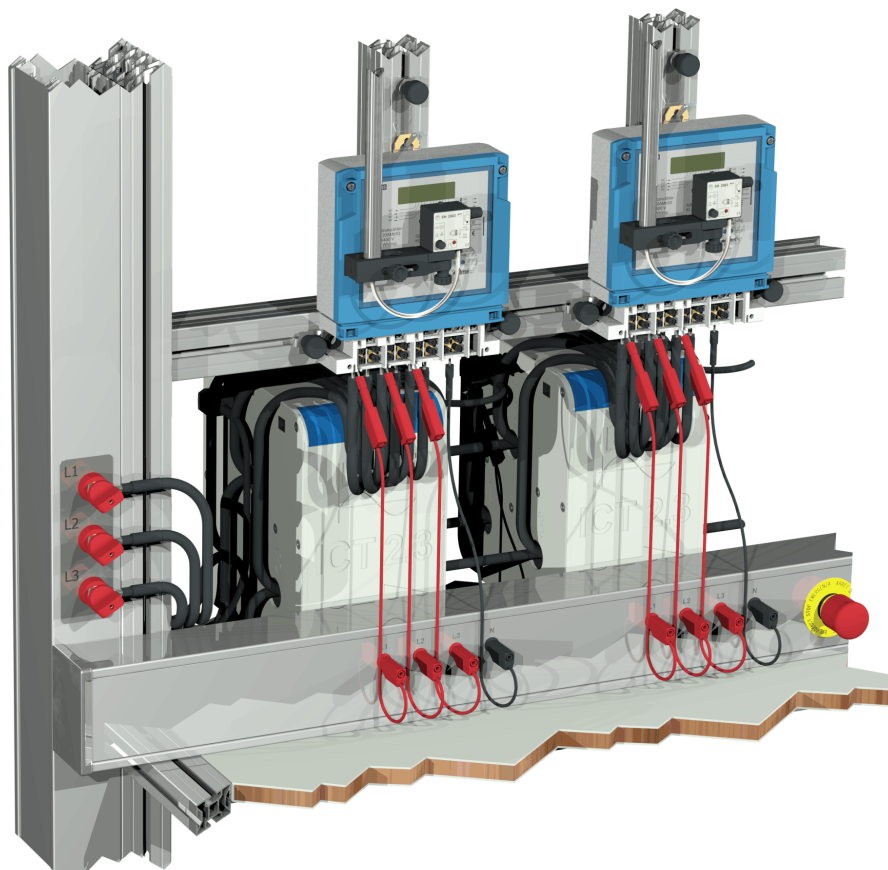
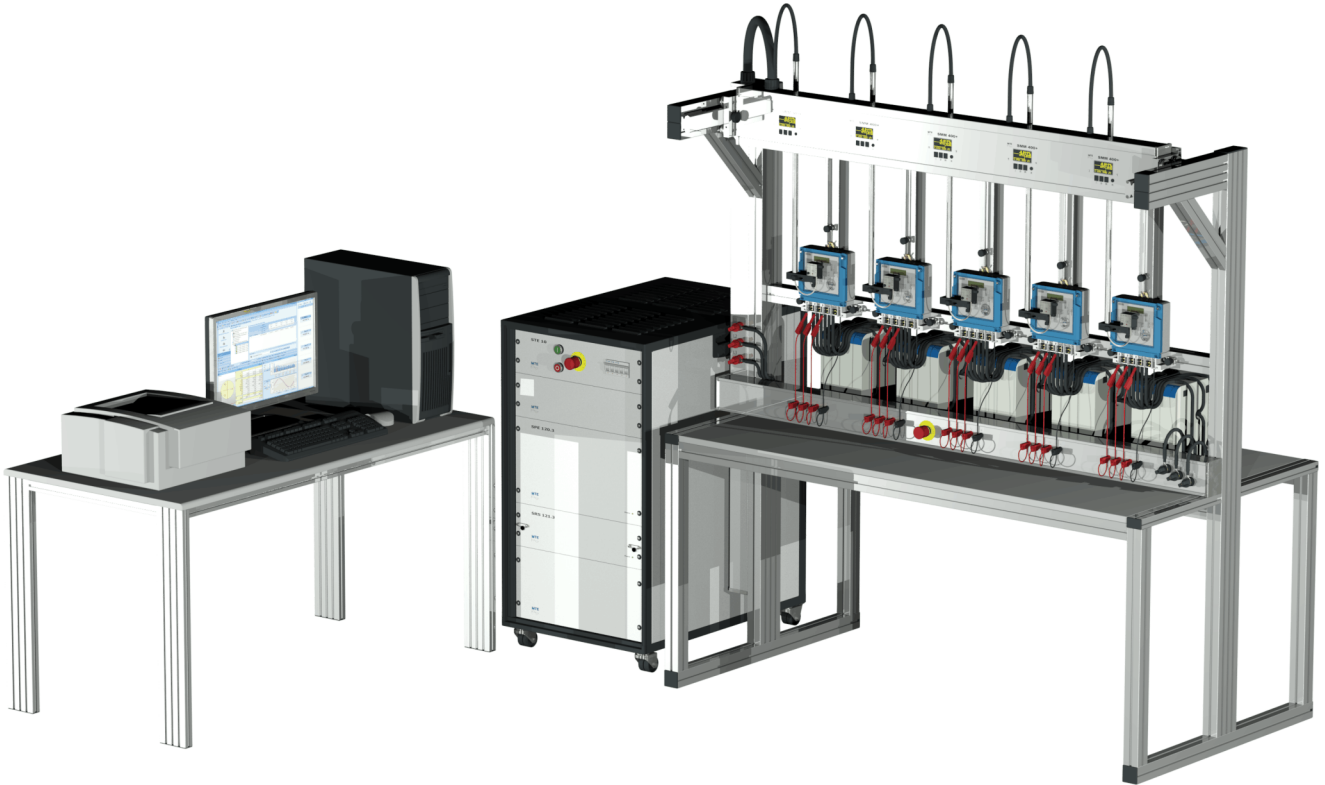

ICT connection at the test bench

Connect auxiliary supply individual to each ICT 2.3 or connect to the first one and pass from ICT to ICT with interconnection cables. Pass the primary current cable phase per phase through the corresponding holes of the isolation current transformer ICT 2.3 and connect them at the current terminals of the test bench. The types of primary and secondary current cables needed depend on the type of the test bench and must be defined at time of order.

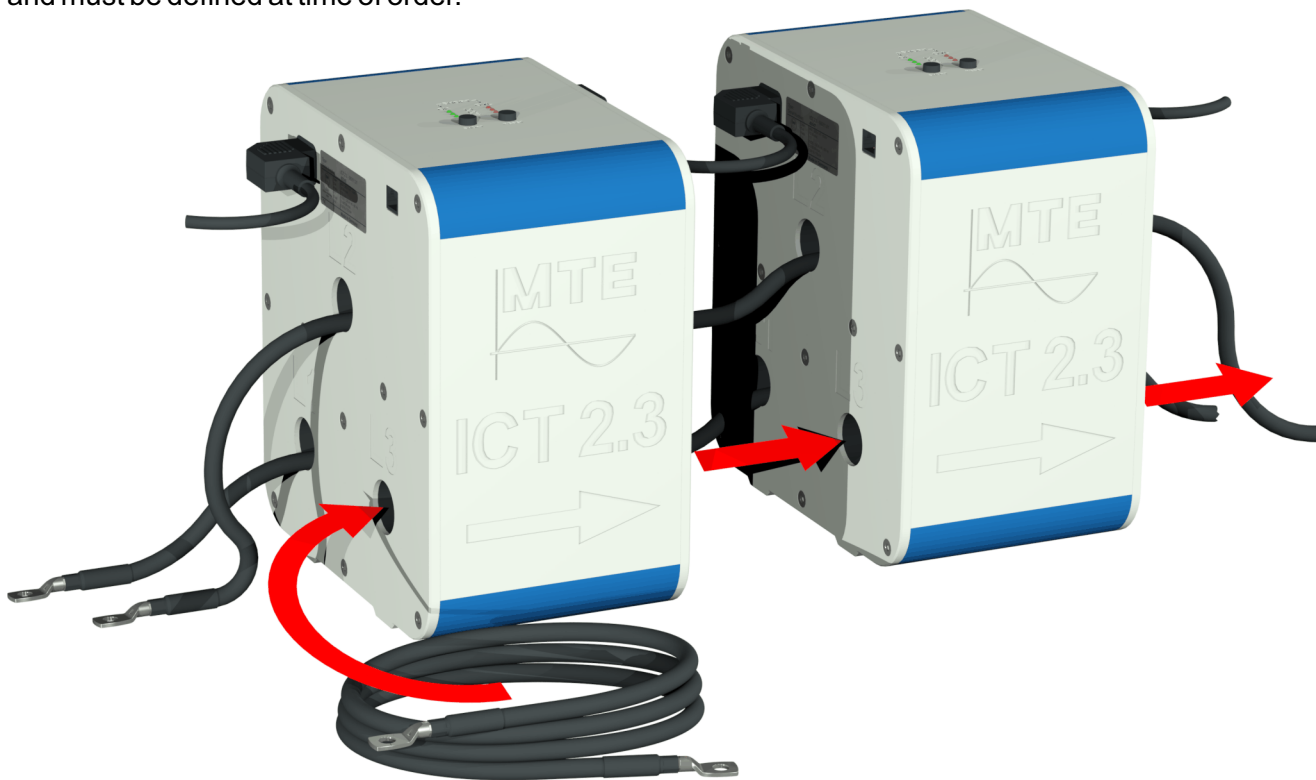

Passing the secondary current cables phase per phase through the corresponding holes. The length of the cables is adapted for use in direct connection or via ICT 2.3.

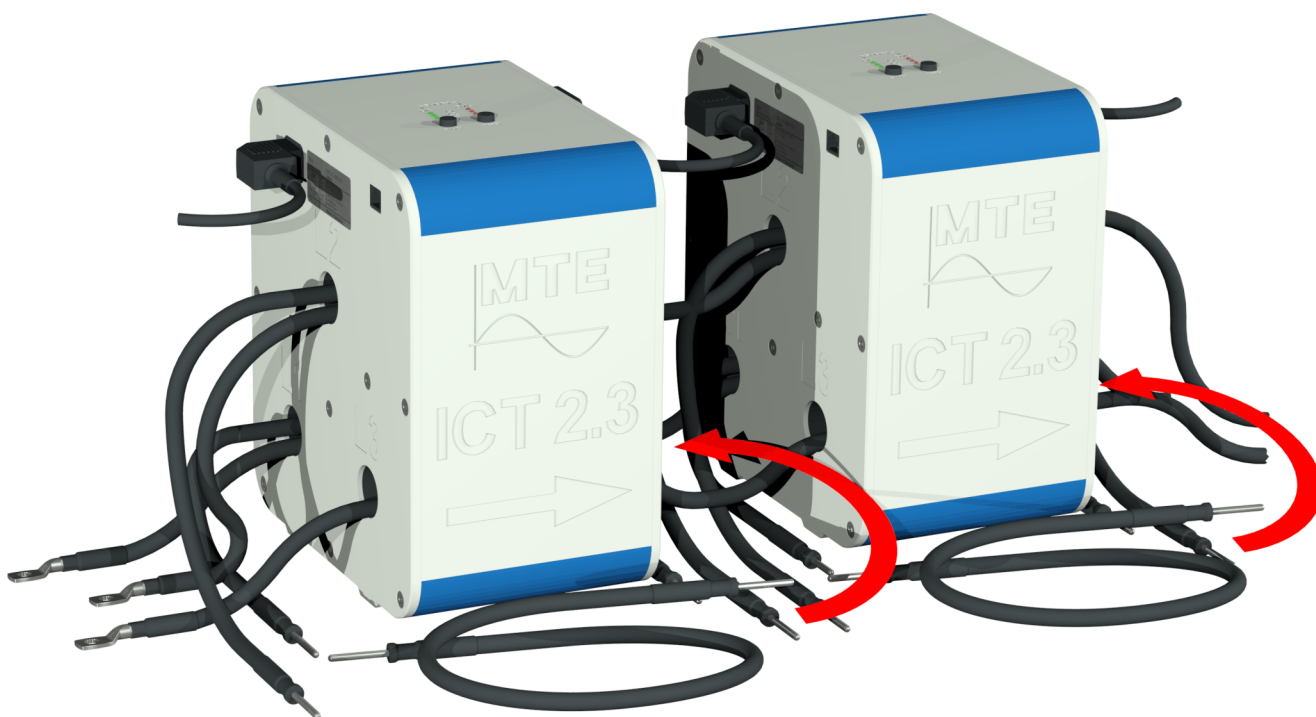

Different types of secondary current cables

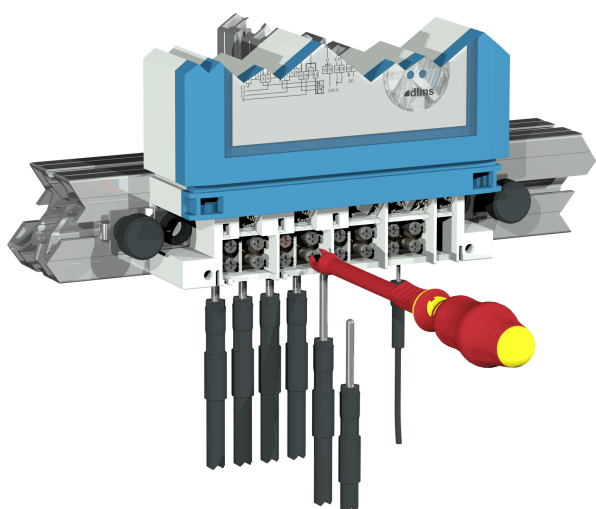

The secondary current cables are equipped with Ø 4 mm fingers. These fingers are assembled at the terminal bloc of the meter like normal current cables.

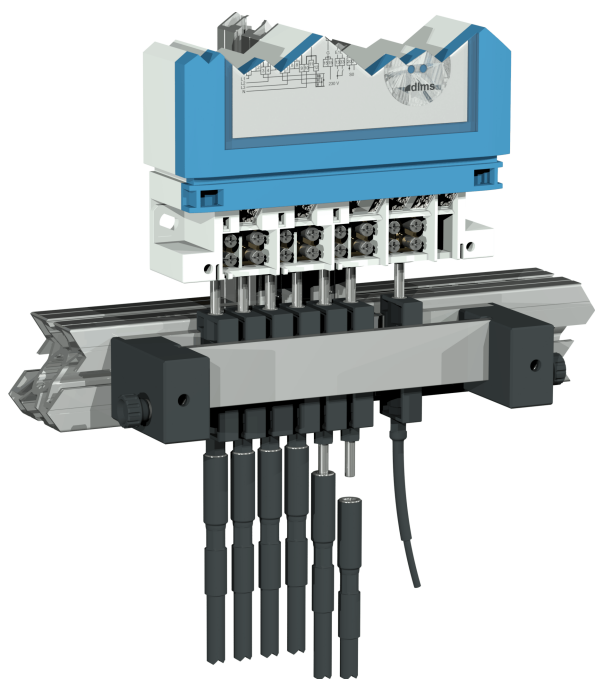

The secondary current cables are equipped with Ø 6 mm sockets. The socket are then linked with the current fingers of the quick connection device QCD 3I or QCD 3IU.

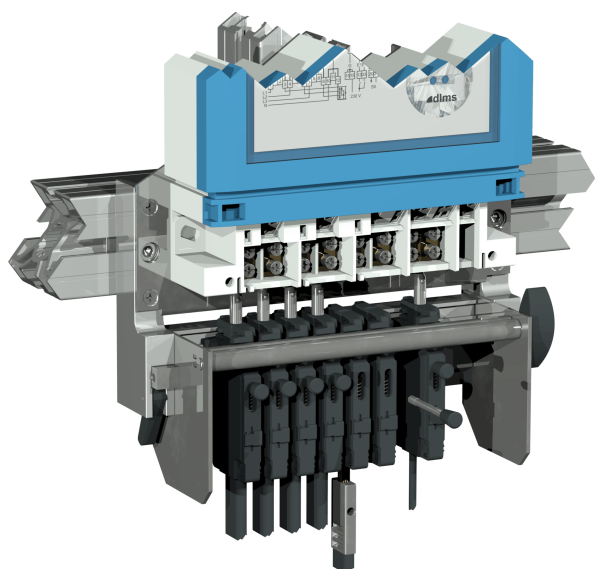

The secondary current cables are equipped with EMP-plugs. These plugs are assembled at the quick connection device EMP 1.3 like normal current cables.



Control Elements and Connections

Status Indication

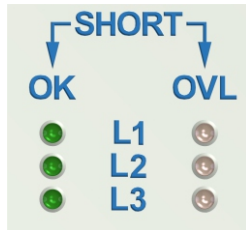

The green LED's indicates normal operation conditions. The ICT 2.3 is switched on and works properly. This indication is valid for the individual phase.

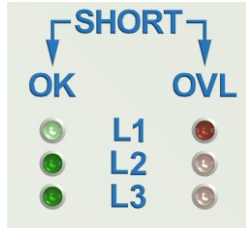

The red LED's indicates that the ICT 2.3 is overloaded in one of the phase (e.g. phase L1) and activate the **AUTOMATIC SHORT CIRCUIT** function.

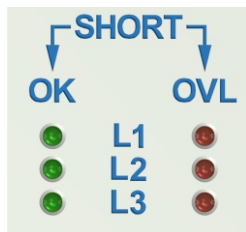

If all red and green LED's light up at the same time, the **MANUAL SHORT CIRCUIT** function was activated.

Push Buttons

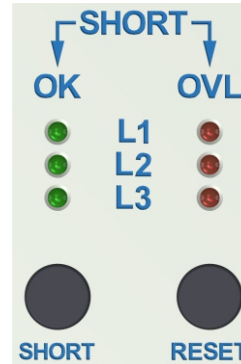

The **SHORT** activate the manual short circuit function. This function works on all phases at the same time and is useful, if not all measurement positions are used.

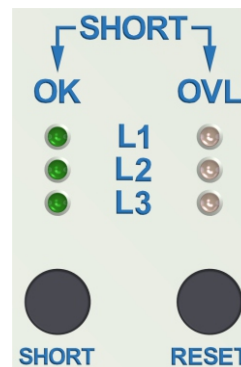

The **RESET** button has two functions:

- ! Reset of the manual short circuit function
- ! Reset of the automatic short circuit function after removal of contact problems at the meter

Connectors for remote control and status indications

With the optional communication box ICU20 the individual ICT's can be controlled and the status can be detected by software.



Left side	Signal and description	Right side
Pin 1	SIGN1 (to control an external LED)	
Pin 2	SIGN2 (to control an external LED)	
Pin 3	SIGN3 (to control an external LED)	
Pin 4	GND	Pin 5
Pin 5	OVL (Overload indication)	Pin 4
Pin 6	SHRT-EX (remote control of SHORT button)	Pin 3
Pin 7	RES0-EX (reset of automatic short circuit function)	Pin 2
Pin 8	RES1-EX (reset of manual short circuit function)	Pin 1

General characteristics

Auxiliary supply:	85 VAC _{min} ... 265 VAC _{max} / 47 Hz ... 63 Hz
Power consumption:	max. 15 VA
Housing:	Hard plastic
Dimensions:	W 152 x D 238 x H 262 mm
Operation temperature:	-10 °C ... +50 °C
Storage temperature:	-20 °C ... +60 °C
Weight:	approx. 17 kg
Temperature Coefficient:	≤ 0.003 %/°C (+0°C ... +15°C / +25°C ... +40°C) ≤ 0.005 %/°C (-10°C ... +0°C / +40°C ... +50°C)

Transformer characteristics

Nominal frequency f _n :	50 Hz (45 ... 55 Hz) or 60 Hz (54 ... 66 Hz)
Ratio:	1:1 (primary current = secondary current)
Current range:	10 mA ... 200 A
Cable hole diameter / length:	30 mm / 0.15 m
Class:	0.05 (100 mA ... 200 A)

Output power (per phase)								
Current range:	200 A	120 A	100 A	80 A	60 A	10 A	1 A	100 mA
Output power max.:	100 VA	60 VA	50 VA	40 VA	30 VA	5 VA	50 mVA	0.5 mVA
Primary loss max.:	(1) 2.4 VA (2)	0.86 VA 1.73 VA	0.6 VA 1.2 VA	0.38 VA 0.77 VA	0.22 VA 0.43 VA	insignificant		
Input burden: (only primary cable in hole)	(1) 0.06 mΩ (cable cross section: 50 mm ² / cable length: 0.15 m) (2) 0.12 mΩ (cable cross section: 25 mm ² / cable length: 0.15 m)							

Output burden (per phase)								
	1 A ... 200 A						100 mA ... 1 A	
Current range:	200 A	120 A	100 A	80 A	60 A	10 A	1 A	100 mA
Output burden max.:	2.5 mΩ	4.2 mΩ	5.0 mΩ	6.3 mΩ	8.3 mΩ	50 mΩ	50 mΩ	50 mΩ
Output burden voltage:	0.5 V						50 mΩ * I	

Error			
Current range:	100 mA ... 200 A (whole output burden range)	25 mA ... 100 mA (whole output burden range)	10 mA ... 25 mA (whole output burden range)
Ration error:	≤ ± 0.02 % (typical) ≤ ± 0.05 % (max.)	≤ ± 0.10 % (typical) ≤ ± 0.20 % (max.)	≤ ± 0.50 % (typical)
Angle error:	≤ ± 0.8 min	≤ ± 1.5 min	≤ ± 3 min
Range: Typical (max.) error of meter test system with ICT 2.3	cos φ = 1 cos φ = 0.5c ... 1 ... 0.5i	cos φ = 1 cos φ = 0.5c ... 1 ... 0.5i	cos φ = 1 cos φ = 0.5c ... 1 ... 0.5i
ICT 2.3 + K2006 (Class 0.01)	≤ ± 0.025 % (0.06 %) ≤ ± 0.04 % (0.12 %)	≤ ± 0.045 % (0.11 %) ≤ ± 0.09 % (0.22 %)	≤ ± 0.14 % (0.21 %) ≤ ± 0.49 % (0.99 %)
ICT 2.3 + SRS 400.3 (Class 0.02)	≤ ± 0.03 % (0.07 %) ≤ ± 0.05 % (0.14 %)	≤ ± 0.05 % (0.12 %) ≤ ± 0.10 % (0.24 %)	≤ ± 0.15 % (0.22 %) ≤ ± 0.50 % (1.00 %)
ICT 2.3 + SRS 121.3 (Class 0.05)	≤ ± 0.05 % (0.10 %) ≤ ± 0.10 % (0.20 %)	≤ ± 0.10 % (0.15 %) ≤ ± 0.15 % (0.30 %)	≤ ± 0.15 % (0.25 %) ≤ ± 0.50 % (1.00 %)

The following MTE leaflets are available:

Overviews:	Company Portrait / Portable Test Equipment / Stationary Meter Test Systems Automatic Test Systems / Transformer Monitoring / E-Mobility Testing
Comparator:	K2008
Portable Reference Standards:	PRS 600.3 / CALPORT 300
Portable Working Standards:	PWS 3.3 <i>genX</i> / PWS 2.3 <i>genX</i>
Portable Standards:	CheckMeter 2.3 <i>genX</i>
Portable Test Systems:	PTS 400.3 PLUS / PTS 3.3 <i>genX</i> / PTS 2.3 <i>genX</i> CheckSystem 2.3 / CheckSystem 2.1 / CheckSystem 2.1 S
Portable Power Sources:	PPS 400.3 / PPS 3.3 <i>genX</i> / CheckSource 2.3
Software:	CALegration®

MTE Meter Test Equipment

MTE Meter Test Equipment AG

Landis + Gyr-Strasse 1
P.O. Box 7550
CH-6302 Zug, Switzerland
Phone: +41 41 508 39 39
Internet: www.mte.ch
e-mail: info@mte.ch

EMH Energie-Messtechnik GmbH

Vor dem Hassel 2
D-21438 Brackel, Germany
Phone: +49 4185 58 57 0
Fax: +49 4185 58 57 68
Internet: www.emh.eu
e-mail: info@emh.de

MTE India Private Ltd.

Commercial Unit - 118 & 119, First Floor
Plot No. 10, Aggarwal City Square, District Centre,
Mangalam Place, Rohini Sector-3, Delhi 110085, India
Phone: +91 11 40218105
E-Mail: info@mteindia.in

EMH Energie-Messtechnik (Beijing) Co. Ltd.

Section 305, Building 2, Ke-Ji-Yuan
Nr.1 Shangdi-Si-Jie, Shangdi-Information-Industry-Base
Haidian District
Beijing 100 085, P.R. China
Phone: +86 10 629 81 227
Mobile: +86 139 0 103 6875
Fax: +86 10 629 88 689
e-mail: guo@emh.com.cn

MTE Meter Test Equipment (UK) Ltd

4 Oval View
Woodley Stockport
Cheshire SK6 1JW, United Kingdom
Phone: +44 161 406 9604
Fax: +44 161 406 9605
e-mail: info@mte.uk.net

MTE Meter Test Equipment Inc.

4949 S Syracuse, Suite 550
Denver, CO - 80237, USA
Phone: +1 888 888 8888
e-mail: info@mteus.com



MTE Meter Test Equipment AG

 Landis + Gyr-Strasse 1 • P.O. Box 7550 • 6302 Zug • Switzerland
Phone +41-41 508 39 39 • Internet www.mte.ch

09.2017_R09
Subject to alterations